



The Green Solution

3.5" SureSeal® MODEL #SS3509V

INLINE FLOOR DRAIN TRAP SEALER



Specification: SureSeal model SS3509V Waterless In-line 3.5" Drain Trap Seal. HDPE (High Density Poly Ethylene) housing with proprietary EPDM rubber diaphragm and soft rubber sealing gasket. Floor rating ASSE 1072 AF GW.

Function: Installed into drain strainers or drain hubs to protect the trap seal from evaporation. Creates a physical barrier that blocks sewer gases and their odors from escaping. Provides waterless trap seal protection equivalent to water based trap primers.

- **New Construction:** Used as a trap primer replacement or in conjunction with a trap primer to provide protection against escaping sewer gases. Eliminates the need to repair/replace trap primers when they fail.
- **Retrofit:** Used in situations where trap primers have failed or where trap primers were never installed.

Benefits: Simple to install, eliminates the need for complex, time consuming, and expensive repairs. ECO friendly providing 100% water savings efficiency over traditional methods.

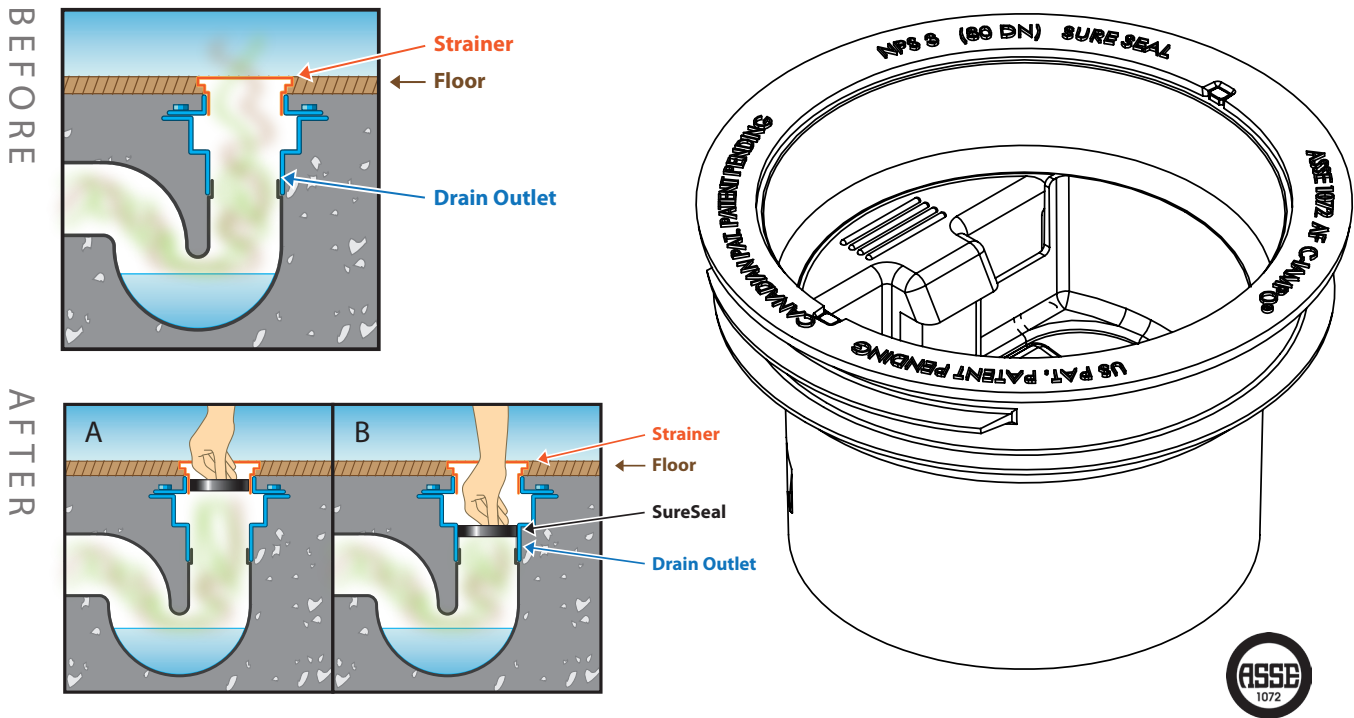

ICC-ES Listed: PMG-1070 IAPMO Listed: C-4165

U.S. Patent 9,010363

Other Patent Pending

